

Jim Hurst
Chair

Doug Albin
Vice Chair

Richard Shoemaker
Commissioner

Dan Platt
Commissioner

Grant Downie
Commissioner

Anna Neumann
Harbormaster

Noyo Harbor Commission Regular Meeting Agenda

Thursday April 11th, 2024

Fort Bragg Town Hall

363 N. Main Street, Fort Bragg, CA 95437

Call to Order

Roll Call

Pledge of Allegiance

Public Comment on Non-Agenda Items

The Noyo Harbor Commission welcomes input from the public. Please limit your comments to five minutes so that everyone may be heard. The Brown Act does not allow action to be taken on non-agenda items.

Correspondence

Jade Tippett – Mendocino Railway

Consent Calendar

1. Meeting Minutes – March 2024
2. Treasurer Report -March 2024

Conduct of Business

1. Discussion and possible action on Blacktail Insurance
2. Discussion on Fleet Meeting
3. Discussion and possible action EDD Grant Update
4. Discussion on MCOG Noyo Harbor Multimodal Circulation Plan

5. Discussion and possible action on making the Marina Manager position a full-time position.
6. Discussion and possible action on Financial Services RFQ

Staff Reports and Recommendations

District Office:

Reminder for April 23rd Special Meeting Noyo Center for Marine Science

Application for Marina Redevelopment for State Coastal Conservancy

Attorney Report:

Matters from the Commissioners:

Adjournment to the next regular meeting May 9th 2024 at 6pm

NOYO HARBOR DISTRICT
STATEMENT OF ACCOUNTS
31-Mar-24

Chase Checking	\$98,929.03
Chase Money Market	\$756,107.84
LAIF	\$1,536,673.10
Total of all accounts	\$2,391,709.97
Funds Reserved for State Lands Commission Grant	\$115,294.87
Funds Reserved for Economic Development Grant	\$653,786.32
Unsecured funds	\$1,622,628.78

Noyo Harbor District
Profit & Loss
March 2024
Mar 24

Ordinary Income/Expense	
Income	
CA Jobs First Meetings	200.00
Electricity	1,997.69
Late Fees	652.64
Park & Launch	5,417.00
Slip Rental Contract	56,134.34
Slip Rental Transient	8,105.11
Total Income	<u>72,506.78</u>
Gross Profit	72,506.78
Expense	
Advertising Expense	43.28
Communications Expense	324.53
Dues and Subscriptions Exp	27.95
Emp. Health & Dental Insurance	2,201.84
Fuel Expense	141.98
Legal and Professional Fees	4,413.25
Office Expense	1,018.05
Operating Supplies	466.94
Payroll Tax Expense	473.55
Power	7,028.48
Repairs & Maintenance	1,698.62
Salary Expense	4,708.61
Sep. Ira	748.95
Utilities Expense	8,732.37
Wages Expense (Hourly)	6,557.09
Total Expense	<u>38,585.49</u>
Net Ordinary Income	33,921.29
Other Income/Expense	
Other Income	
EDD-CERF	<u>662,000.00</u>
Total Other Income	662,000.00
Other Expense	
EDD Project	7,517.86
FEMA 4683	5,410.00
SLC Fish Cleaning Station	657.50
SLC Vessel Demo	4,792.50
Total Other Expense	<u>18,377.86</u>
Net Other Income	643,622.14
Net Income	<u><u>677,543.43</u></u>

	TOTAL			
Ordinary Income/Expense	FY Year to Date	FY TD Budget	FY Budget	% of Total Budget
Income				
Electricity	\$10,418.23	6,666.67	\$10,000.00	104.18
Encroachment Leases	\$24,759.36	13,333.33	\$20,000.00	123.80
Fish Markets	\$2,362.00	2,000.00	\$3,000.00	78.73
Ground Rent	\$1,498.64	20,000.00	\$30,000.00	5.00
Hoist Fees	\$0.00	666.67	\$1,000.00	0.00
Income / Mdco. County				
Taxes	\$81,899.89	78,173.33	\$117,260.00	69.84
Interest Income	\$32,664.51	20,000.00	\$30,000.00	108.88
Late Fees	\$2,083.61	1,333.33	\$2,000.00	104.18
Main Pier	\$200.00	666.67	\$1,000.00	20.00
Other Grant Proceeds	\$200.00	13,333.33	\$20,000.00	1.00
Park & Launch	\$30,774.00	16,666.67	\$25,000.00	123.10
Slip Rental Contract	\$322,005.60	304,000.00	\$456,000.00	70.62
Slip Rental Transient	\$36,192.82	28,666.67	\$43,000.00	84.17
Total Income	\$545,058.66	505,506.67	\$758,260.00	71.88
Expense				
Advertising Expense	\$249.74	5,333.33	\$8,000.00	3.12
Communications Expense	\$3,396.17	3,000.00	\$4,500.00	75.47
Deferred Maintenance	\$0.00	6,666.67	\$10,000.00	0.00
Dues and Subscriptions Exp	\$9,626.06	6,666.67	\$10,000.00	96.26
Emp. Health & Dental				
Insurance	\$21,542.00	16,000.00	\$24,000.00	89.76
Fuel Expense	\$2,464.11	3,333.33	\$5,000.00	49.28
Insurance Property & Liability	\$218,652.56	140,000.00	\$210,000.00	104.12
Legal and Professional Fees	\$29,351.85	38,333.33	\$57,500.00	51.05

Office Expense	\$6,341.11	7,866.67	\$11,800.00	53.74
Operating Supplies	\$4,059.16	4,666.67	\$7,000.00	57.99
Payroll Tax Expense	\$11,660.72	11,333.33	\$17,000.00	68.59
Power	\$42,374.96	36,666.67	\$55,000.00	77.05
Refund	\$707.10	666.67	\$1,000.00	70.71
Repairs & Maintenance	\$22,546.74	18,666.67	\$28,000.00	80.52
Salary Expense	\$53,827.12	46,666.67	\$70,000.00	76.90
Sep. Ira	\$6,267.34	5,400.00	\$8,100.00	77.37
Taxes & Assessments	\$1,472.99	2,000.00	\$3,000.00	49.10
Travel and Conferences	\$1,750.49	3,333.33	\$5,000.00	35.01
Utilities Expense	\$55,196.87	45,333.33	\$68,000.00	81.17
Wages Expense (Hourly)	\$90,448.58	77,333.33	\$116,000.00	77.97
Total Expense	\$581,935.67	479,266.67	\$718,900.00	80.95
Net Income	-\$36,877.01		\$39,360.00	-93.69

Noyo Harbor District

Payroll summary by employee report

From Mar 01, 2024 to Mar 31, 2024 for all employees from all locations

Item	Total
Hours - total	529.84
Hours - Regular Pay	354.5
Hours - Vacation Pay	2
Hours - Holiday Pay	0
Hours - Salary	173.34
Gross pay - total	\$ 13,673.62
Gross pay - Regular Pay	\$ 7,969.34
Gross pay - Vacation Pay	\$ 54.28
Gross pay - Holiday Pay	\$ 0.00
Gross pay - Salary	\$ 5,650.00
Pretax deductions - total	
Adjusted gross	\$ 13,673.62
Other pay - total	\$ 0.00
Employee taxes & deductions - total	-\$ 2,407.92
Employee taxes - total	-\$ 2,407.92
Employee taxes - Federal Income Tax	-\$ 935.61
Employee taxes - Social Security	-\$ 847.76
Employee taxes - Medicare	-\$ 198.28
Employee taxes - CA Income Tax	-\$ 275.86
Employee taxes - CA State Disability Ins	-\$ 150.41
Employee Aftertax deductions - total	
Net pay	\$ 11,265.70
Employer taxes & contributions - total	\$ 1,129.17
Employer taxes - total	\$ 1,129.17
Employer taxes - FUTA Employer	\$ 20.78
Employer taxes - Social Security Employer	\$ 847.76
Employer taxes - Medicare Employer	\$ 198.28
Employer taxes - CA ETT	\$ 3.47
Employer taxes - CA SUI Employer	\$ 58.88
Company contributions - total	
Total payroll cost	\$ 14,802.79

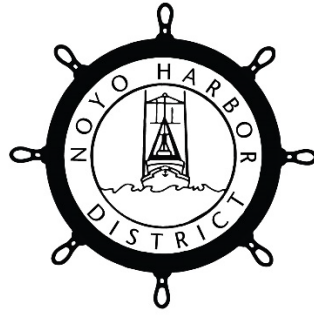

Page Left Blank

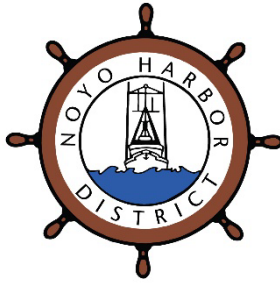

Jim Hurst
Chair

Doug Albin
Vice Chair

Richard Shoemaker
Commissioner

Dan Platt
Commissioner

Grant Downie
Commissioner

Anna Neumann
Harbormaster

Noyo Harbor Commission Regular Meeting Minutes

Thursday March 14th, 2024

Fort Bragg Town Hall

363 N. Main Street, Fort Bragg, CA 95437

Call to Order at 6:02pm

Roll Call

Present: Commissioners Downie, Vice Chair Albin, Chair Hurst

Absent: Commissioner Shoemaker, Commissioner Platt

Staff Present: Anna Neumann, Jim Jackson

Pledge of Allegiance

Public Comment on Non-Agenda Items

Dennis Miller asked about travel lifts for the Harbor District. A short discussion was held on the pros and cons of various travel lift styles.

Correspondence

None

Consent Calendar

1. Meeting Minutes – February 2024
2. Treasurer Report -February 2024

Motion to approve the Consent Calendar: 1st Commissioner Downie, 2nd Vice Chair Albin.

Passed 3-0-2

Conduct of Business

1. Discussion and possible action on letter to PMFC

Commissioners and the Harbormaster discussed upcoming fishing regulations and how they will affect the Noyo Harbor District. Harbormaster wanted to get input from Commissioner Platt who is heavily involved in the management of fisheries locally to ensure the letter is accurate and reflects the concerns of the District. Anna communicated that Commissioner Platt had offered to read the letter into the public record at the Pacific Fisheries Management Council Meeting.

Motion to approve the letter after input from Commissioner Platt. 1st Commissioner Downie, 2nd Vice Chair Albin. Approved 3-0-2

2. Discussion and possible action on Resolution 2024-1 Oil Spill Equipment Grant

A short discussion on the benefits of the Oil Spill Equipment Grant was held in the Harbor District. The grant is 100% funded and oil spill absorbent materials are critical to have on hand when a spill occurs.

Motion to approve Resolution 2024-1 Oil Spill Equipment Grant Program. 1st Commissioner Downie, 2nd Vice Chair Albin. Approved 3-0-2

3. Discussion on Port Infrastructure Development Grant

Commissioner Downie arrived at 6:33pm

A discussion was held about the Port Infrastructure Development Grant program by the Department of Transportation Maritime Administration. The Harbormaster met with the staff of the PIDP program and reviewed the strengths and weaknesses of the District's application to the FY2023 program. The Harbormaster shared the review with the commissioners and noted that none of the advice given to strengthen the application was outside of the District's ability to implement.

Motion to direct harbormaster to reapply for the FY2024 PIDP program. 1st Vice Chair Albin, 2nd Commissioner Downie. 4-0-1

4. Discussion on EDD project

The Harbormaster gave updates on the EDD project, including an overview of her trip to Bellingham to attend the Wild Connection Seafood Conference with Mary Ann Petrillo from West Center.

A discussion was held on if the District should hold off on moving forward with permitting the icehouse at the High Dock location or continuing to attempt to purchase the Tommys Property. This action could lead to the District not completing the project on time. The commission thought it was prudent to move forward with permitting at the High Dock location and not jeopardize the timelines of the EDD grant program.

No motion was made.

5. Discussion on Fish Cleaning Station

The Harbormaster reported that they hope to bring contracts for the construction of the fish cleaning station to the commission at the April meeting. Construction would start after the 4th of July Salmon BBQ and hopefully be completed by tuna season in September.

No motion was made.

Staff Reports and Recommendations

District Office:

Update on hiring process for Marina Manager position and Bookkeeper

Special Meeting for Blue Economy Feasibility Plan- Noyo Center for Marine Science

Attorney Report:

None

Matters from the Commissioners:

Commissioner Platt confirmed that he would be attending the PMFC meeting and would read the letter into public comment.

Commissioner Downie reported on his participation in the last sea otter re-introduction meeting.

Adjournment to the next regular meeting of April 11th 2024 6pm at 7:40 pm.



Page Left Blank

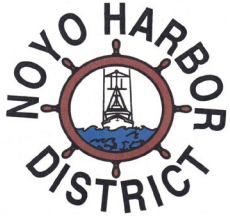

NOYO HARBOR DISTRICT AGENDA ITEM SUMMARY

AGENDA ITEM #: 1
MEETING DATE: 4/11/2024

TITLE

Blacktail Insurance

RECOMMENDED ACTION

ANALYSIS

The Harbor District's insurance agent Mr. Hall is leaving Newfront Insurance and starting his own agency. He has an agreement with Newfront where he can take his smaller clients. The Harbor District is considered to be a smaller client.

Mr. Hall has successfully negotiated lower rates for the Harbor District in the past and has always been receptive and responsive to the needs of the District. Before his departure with Newfront he was in the process of shopping around the marina's insurance policy to other businesses and he felt he could continue to get competitive rates for the District in the future. Mr. Hall has shown that he has strong contacts within the insurance industry and transitioning to Mr. Hall's new company would not hinder the District's ability to get competitive rates.

We have not been contacted by Newfront as to who our new agent would be if we stayed with Newfront.

FISCAL IMPACT

ATTACHMENTS

None



Page Left Blank



NOYO HARBOR DISTRICT AGENDA ITEM SUMMARY

AGENDA ITEM #: 2
MEETING DATE: 4/11/2024

TITLE

Fleet Meeting

RECOMMENDED ACTION

ANALYSIS

Due to the fact that there are several projects happening in and around the Harbor, and multiple groups want input from the commercial fleet, the Harbormaster would like to host a fleet meeting at the Noyo Fish Company on April 22nd from 4-7pm.

At the fleet meeting the Harbormaster will present the progress made on the flake ice house and introduce the West Center staff and Marine Based Entrepreneurial Training Program. We will be asking the fleet to fill out a form that indicates which programs they want to participate in within the Marine Training Program.

The Harbormaster will also present the Blue Economy Visioning Resiliency and Implementation Plan lead by the City of Fort Bragg. We will be asking for the fleets input on City policy that involves the Harbor and the Fishing Village Zoning.

The Noyo Center for Marine Science will also have an opportunity to receive feedback from the fleet about their Blue Economy Feasibility Plan.

The Mendocino Council of Governments has recently been funded for the North Harbor Circulation Feasibility Plan. The Harbormaster will inform the fleet of this project.

All commercial fishermen and their crew members, businesses in N. Harbor, Charter Boat Business, Fish Buyers and Processors are invited to the meeting.

FISCAL IMPACT

None

ATTACHMENTS

None

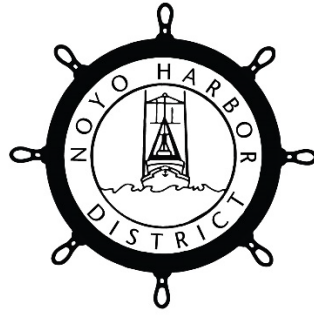

Page Left Blank

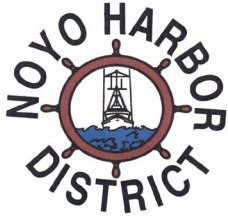

NOYO HARBOR DISTRICT AGENDA ITEM SUMMARY

AGENDA ITEM #: 3
MEETING DATE: 4/11/2024

TITLE

Update on Icehouse

RECOMMENDED ACTION

ANALYSIS

Harbor staff and SHN have moved forward with designing the icehouse system to deliver ice off the High Dock. Attached are the preliminary drawings developed by SHN. Surrounding the Icehouse would be a wooden structure that would allow staff to access all levels of the systems. SHN has developed these plans in conjunction with North Star to ensure that our plans meet the specifications of the North Star systems.

The next step in this process is to approve the purchase of the ice system from North Star and send the deposit. The Economic Development Department has awarded the pre-payment to the Harbor District and there are funds in our account to transfer \$600,000 to North Star Ice. This transfer of funds would secure our purchase at the quoted price of \$1,365,498.00.

In the EDD grant the Harbor District estimated that the icehouse would cost \$1,700,000. This leaves a buffer of \$334,500. An additional \$405,000 was budgeted for site preparations, trenching water and power, installing the delivery system and fixing rusted elbow on the water main. With the reduced price on the icehouse the Harbor District has \$739,500 to complete the accessory work around the icehouse installation.

FISCAL IMPACT

This project is funded at 100%.

ATTACHMENTS

Designs by SHN

North Star Quote

NOYO HARBOR DISTRICT ICE HOUSE

19101 SOUTH HARBOR DR.
FORT BRAGG, CALIFORNIA

PREPARED BY:



MARCH 2024



INDEX OF SHEETS

SEQ	SHT	TITLE
1	G1.0	COVER
2	G2.0	STANDARD ABBREVIATIONS AND LEGENDS
3	C1.0	DEMOLITION PLAN
4	C2.0	SITE PLAN
5	C2.1	ENLARGED SITE PLAN
6	C3.0	PROFILE
7	C4.0	DETAILS
8	C4.1	DETAILS
9	A1.0	ELEVATIONS

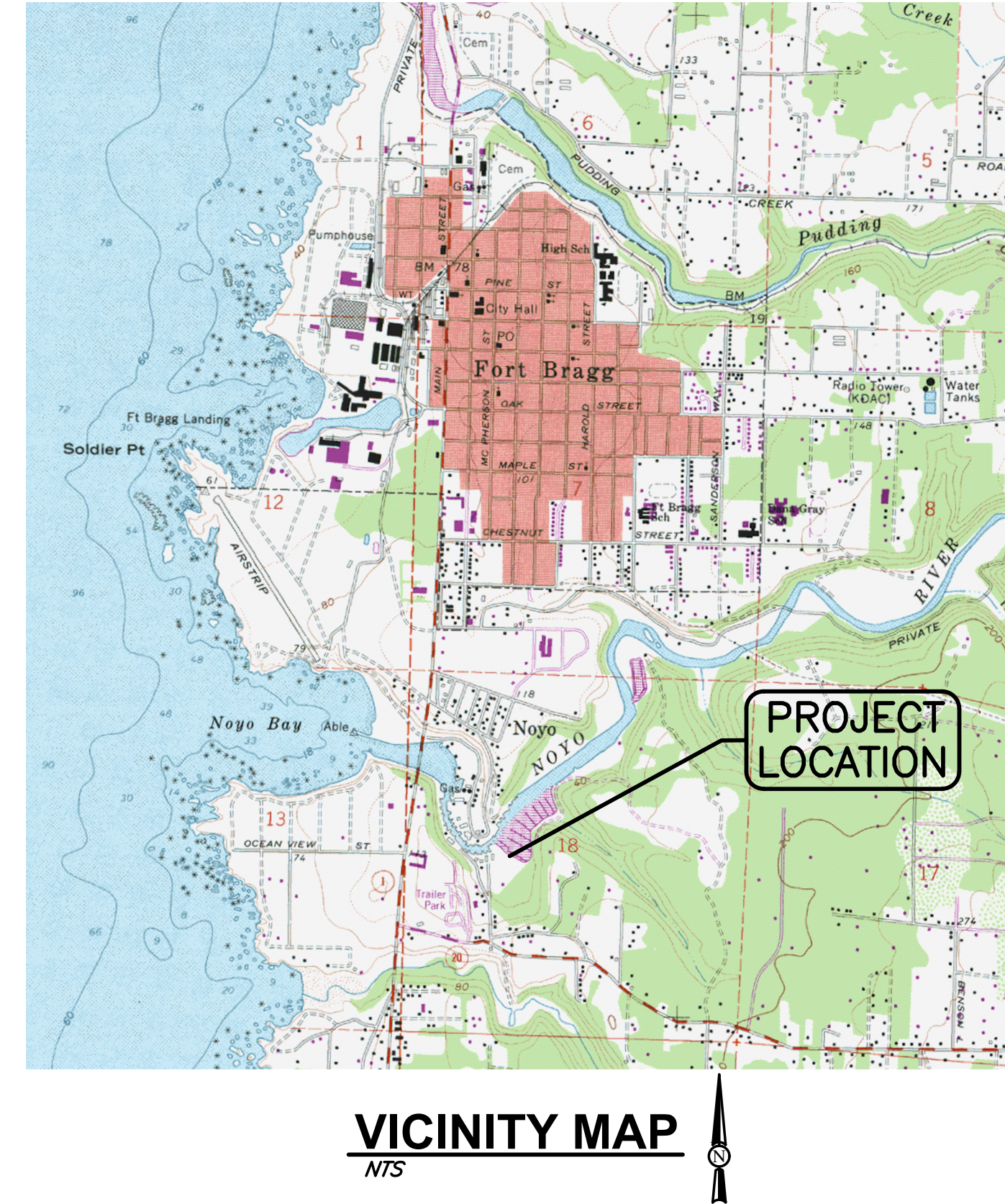

SAVED: 3/20/2024 3:39 PM JNAULTY, PLOTTED: 3/26/2024 8:32 AM JUSTIS NAULTY
 P:\Willits\2021\421058-Noyo-CSP\106-ice-Plant\Drawings\421058-106-COVER.dwg

VERIFY SCALES
 BAR IS ONE INCH ON ORIGINAL DRAWING
 IF NOT ONE INCH ON THIS SHEET ADJUST SCALES ACCORDINGLY

535 S. MAIN ST.
 WILLITS, CA. 95490
 WWW.SN-ENR.COM
 707-499-4518



NO.	DATE	REVISION	BY

NOYO HARBOR DISTRICT
 ICE HOUSE
 19101 S HARBOR DR., FORT BRAGG, CALIFORNIA
 COVER

SHEET
G1.0
 SEQ
 DATE **03/2024**
 PROJ. NO.
 421058.106

PRELIMINARY

ABBREVIATIONS

A	ABN — ABANDON	G	GA — GAS	R	RC — RADIUS
ABS — ACRYLONITRILE-BUTADIENE-STYRENE	GB — GAGE	RC — RELATIVE COMPACTION	GALV — GALVANIZED	RCP — REINFORCED CONCRETE PIPE	RD — ROAD
AB — ANCHOR BOLT, AGGREGATE BASE	GIP — GALVANIZED IRON PIPE	RCDR — REDUCER	GM — GAS METER	RWD — REDWOOD	REF — REFER OR REFERENCE
ABD — ABANDON	GPD — GALLONS PER DAY	REF — REFER OR REFERENCE	GPH — GALLONS PER HOUR	REIN — REINFORCED, REINFORCING OR REINFORCE	REIN — REINFORCED, REINFORCING OR REINFORCE
AC — ASPHALTIC CONCRETE	GPM — GALLONS PER MINUTE	REO — REQUIRED	GRD — GRADE OR GROUND	RET — RETURN	RH — RIGHT HAND
ACP — ASBESTOS CEMENT PIPE	GSP — GALVANIZED STEEL PIPE	RET — RETURN	GV — GATE VALVE	RM — ROOM	RO — ROUGH OPENING
ACI — AMERICAN CONCRETE INSTITUTE	GYP — GYPSUM	RH — RIGHT HAND		RSP — ROCK SLOPE PROTECTION	RT — RIGHT OR RING TIGHT
ADJ — ADJUSTABLE		RM — ROOM		R/W — RIGHT OF WAY	RWL — RAIN WATER LEADER
AGGR — AGGREGATE		RSP — ROCK SLOPE PROTECTION			
AISC — AMERICAN INSTITUTE OF STEEL CONSTRUCTION		RT — RIGHT OR RING TIGHT			
AL — ALUMINUM		R/W — RIGHT OF WAY			
ALT — ALTERNATE		RWL — RAIN WATER LEADER			
AP — ANGLE POINT					
APPROX — APPROXIMATELY					
ARCH — ARCHITECTURAL					
ASTM — AMERICAN SOCIETY FOR TESTING & MATERIALS					
AUX — AUXILIARY					
AT — AT					
B					
BC — BEGIN CURVE					
BCR — BEGIN CURB RETURN					
BD — BOARD					
BF — BLIND FLANGE					
BFV — BUTTERFLY VALVE					
BK — BOOK OR BACK					
BLDG — BUILDING					
BMP — BENCH MARK, BEAM					
BMP — BEST MANAGEMENT PRACTICE					
BO — BLOW OFF					
BOT — BOTTOM					
BRG — BEARING					
BTWN — BETWEEN					
BV — BALL VALVE					
BVC — BEGINNING OF VERTICAL CURVE					
BW — BACK OF WALK					
BWV — BACKWATER VALVE					
C					
CA — CHANNEL (STRUCTURAL SHAPE)					
CARV — COMBINATION AIR AND VACUUM RELEASE VALVE					
CATV — CABLE TELEVISION					
CB — CATCH BASIN					
CEIL — CEILING					
CFM — CUBIC FEET PER MINUTE					
CFS — CUBIC FEET PER SECOND					
CHEM — CHEMICAL					
CI — CAST IRON					
CIP — CAST IRON PIPE					
C.I.P. — CAST IN PLACE					
CJ — CONSTRUCTION JOINT					
CLR — CLEAR					
C/CL — CENTERLINE					
CMP — CORRUGATED METAL PIPE					
CMU — CONCRETE MASONRY UNIT					
CTSK — COUNTERSINK					
CO — CLEANOUT					
COL — COLUMN					
CONC — CONCRETE					
CONT — CONTINUOUS OR CONTINUED					
COORD — COORDINATE					
CPLG — COUPLING					
CRS — COLD ROLLED STEEL					
CTR — CENTER					
CUB — COPPER TUBE SIZE					
CU — CUBIC FEET					
CV — CHECK VALVE					
CW — COLD WATER					
CY — CUBIC YARD					
D					
d — DEGREE (ANGLE)					
D — PENNY (NAIL SIZE)					
DB — STORM DRAIN					
DBL — DISTRIBUTION BOX					
DF — DOUBLE					
DF — DOUGLAS FIR					
DI — DROP INLET OR DUCTILE IRON					
DIA — DIAMETER					
DIAG — DIAGONAL					
DIM — DIMENSION					
DIMJ — DUCTILE IRON MECHANICAL JOINT					
DIP — DUCTILE IRON PIPE					
DET — DETAIL					
DWG — DRAWING					
DW — DRIVEWAY					
E					
(E) — EXISTING					
EA — EASTING OR EAST					
EA — EACH					
EC — END CURVE					
ECR — END CURB RETURN					
EF — EACH FACE					
EFL — EFFLUENT					
EG — EXISTING GRADE/GROUND					
ELBOW — ELBOW					
ELEC — ELECTRIC OR ELECTRICAL					
ELEV — ELEVATION					
ENGR — ENGINEER					
EP — EDGE OF PAVING					
EQ — EQUAL					
EQUIP — EQUIPMENT					
ER — EDGE OF ROAD					
EVC — END OF VERTICAL CURVE					
EW — EACH WAY					
EWEF — EACH WAY, EACH FACE					
EXC — EXCAVATE					
EXP — EXPOSED OR EXPANSION					
EXP JT — EXPANSION JOINT					
EXST — EXISTING					
EXT — EXTERIOR					
F					
F — FLANGE					
FC — FLEXIBLE COUPLING OR FACE OF CURB					
FCA — FLANGED COUPLING ADAPTER					
FD — FLOOR DRAIN					
FDC — FIRE DEPARTMENT CONNECTION					
FDN — FOUNDATION					
FF — FINISH FLOOR					
FG — FINISHED GRADE					
FH — FIRE HYDRANT					
FIG — FIGURE					
FIN — FINISH					
FIP — FEMALE IRON PIPE					
FL — FLOW LINE					
FLG — FLANGE					
FLR — FLOOR					
FLTR — FILTER					
FO — FIBER OPTIC					
FOC — FACE OF CONCRETE					
FT — FOOT OR FEET					
FT2 — SQUARE FEET					
FT3 — CUBIC FEET					
FTG — FOOTING					
FUT — FUTURE					
G					
G — GAS					
GA — GAGE					
GALV — GALVANIZED					
GIP — GALVANIZED IRON PIPE					
GM — GAS METER					
GPD — GALLONS PER DAY					
GPH — GALLONS PER HOUR					
GPM — GALLONS PER MINUTE					
GRD — GRADE OR GROUND					
GSP — GALVANIZED STEEL PIPE					
GV — GATE VALVE					
GYP — GYPSUM					
H					
HB — HOSE BIBB					
HDP — HIGH DENSITY POLYETHYLENE					
HDR — HEADER					
HDW — HARDWARE					
HMA — HOT MIX ASPHALT					
HOR — HORIZONTAL					
HP — HORSEPOWER, HIGH POINT					
HR — HOUR					
HT — HEIGHT					
HW — HOT WATER					
HWR — HOT WATER RETURN					
HWS — HOT WATER SUPPLY					
I					
ID — INSIDE DIAMETER					
IN — INCH					
INFL — INFLUENT					
INSUL — INSULATE OR INSULATION					
INT — INTERIOR					
INV — INVERT					
IPS — IRON PIPE SIZE					
J					
JT — JOINT					
JP — JOINT POLE					
K					
KIP — THOUSAND POUNDS					
KW — KILOWATT					
L					
L — ANGLE (DEGREES)					
L — ANGLE (STRUCTURAL SHAPE)					
LAT — LATERAL					
LB — POUND					
LF — LINEAR FEET					
LG — LONG					
LH — LEFT HAND					
LONG — LONGITUDINAL					
LP — LOW POINT					
LPG — LIQUIFIED PETROLEUM GAS					
LRP — LEGALLY RESPONSIBLE PARTY					
LR — LONG RADIUS					
LT — LEFT					
LVC — LENGTH OF VERTICAL CURVE					
M					
MATL — MATERIAL					
MAX — MAXIMUM					
MECH — MECHANICAL					
MF — MEGA-FLANGE PIPE JOINT					
MFR — MANUFACTURER					
MGD — MILLION GALLONS PER DAY					
MH — MANHOLE					
MIN — MINIMUM OR MINUTE					
MIP — MALE IRON PIPE					
MISC — MISCELLANEOUS					
MJ — MECHANICAL JOINT					
MNPT — MALE NATIONAL PIPE THREAD					
MTL — METAL					
MWS — MAXIMUM WATER SURFACE					
N					
(N) — NEW					
N — NORTHING OR NORTH					
NC — NORMALLY CLOSED					
NIC — NOT IN CONTRACT					
NF — NON-FREEZE					
NO — NUMBER OR NORMALLY OPEN					
NOM — NOMINAL					
NP — NEW PAVEMENT					
NPT — NATIONAL PIPE THREAD					
NTS — NOT TO SCALE					
# — NUMBER					
O					
OC — ON CENTER					
OD — OUTSIDE DIAMETER					
OG — ORIGINAL GROUND					
OVFL — OVERFLOW					
OZ — OUNCE					
OH — OVERHEAD					
P					
PC — POINT OF CURVE					
PCC — PORTLAND CEMENT CONCRETE					
PCF — POUNDS PER CUBIC FOOT					
PE — PLAIN END					
PERF — PERFORATED					
PEP — POLYETHYLENE PIPE					
PI — POINT OF INTERSECTION					
PL — PLATE					
PL — PROPERTY LINE					
PLCS — PLACES					
PLYWD — PLYWOOD					
PMP — PERFORATED METAL PIPE					
POC — POINT OF CURVE					
POT — POINT OF TANGENT					
PP — POWER POLE					
PRC — POINT OF REVERSE CURVE					
PREFAB — PREFABRICATED					
PRELIM — PRELIMINARY					
PRESS — PRESSURE					
PROP — PROPERTY					
PRV — PRIVATE					
PSF — POUNDS PER SQUARE FOOT					
PSIG — POUNDS PER SQUARE INCH					
PSG — POUNDS PER SQUARE INCH, GAUGE					
PT — POINT OF TANGENCY, POINT					
PUE — PUBLIC UTILITY EASEMENT					
PV — PLUG VALVE					
PVCL — POLYVINYL CHLORIDE PLASTIC					
PVC — POINT OF VERTICAL INTERSECTION					
PVMT — PAVEMENT					
Q					
QTY — QUANTITY					

CURVE DATA

R	(RADIUS)
L	(LENGTH)
Δ	(DELTA)
T	(TANGENT)

UTILITIES LEGEND

PROPOSED	EXISTING	DESCRIPTION
		GATE VALVE
		PLUG VALVE
		BALL VALVE
		BUTTERFLY VALVE
		AUTOMATICALLY OPERATED VALVE (P= PNEUMATIC, E= ELECTRIC, S= SOLENOID, H= HYDRAULIC, D= DIAPHRAGM ACTUATOR)
		3-WAY VALVE
		GLOBE VALVE

SAVED: 3/13/2024 7:42 AM CNEWELL, PLOTTED: 3/26/2024 8:33 AM JUSTIS MAULTY
 P:\Willits\2021\421058-Noyo-CSP1\Doc-Is-Plant\Drawgs\421058-106-DEMO.dwg

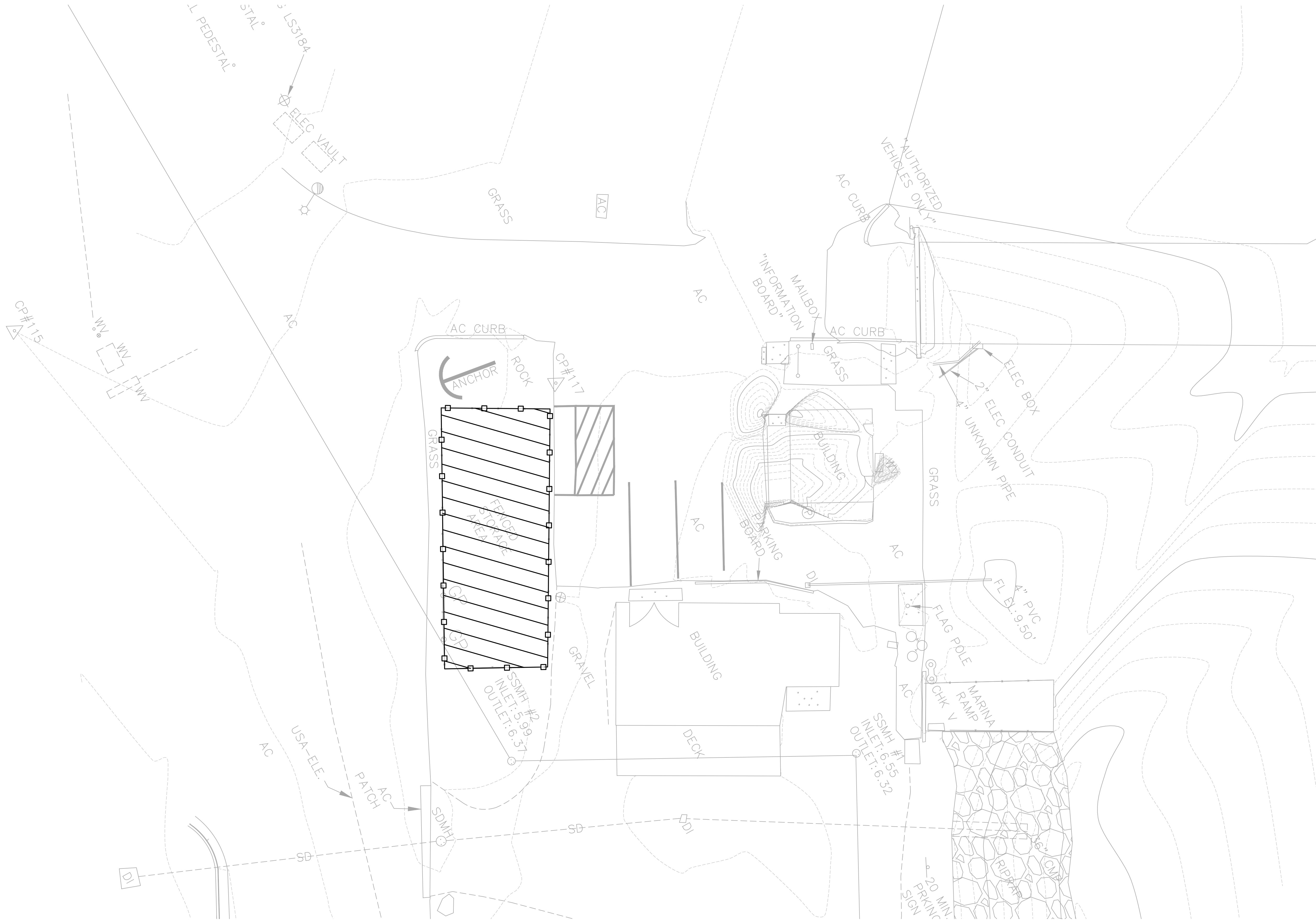

PLAN
 1"=10'



PRELIMINARY

VERIFY SCALES
 BAR IS ONE INCH ON ORIGINAL DRAWING
 IF NOT ONE INCH ON THIS SHEET ADJUST SCALES ACCORDINGLY

535 S. MAIN ST
 WILLITS, CA 95490
 WWW.S&H-ENR.COM
 707-439-4518



NO.	DATE	REVISION	BY

NOYO HARBOR DISTRICT
 ICE HOUSE
 19101 S HARBOR DR., FORT BRAGG, CALIFORNIA
DEMOLITION PLAN

SHEET	C1.0
SEQ	
DATE	03/2024
PROJ. NO.	421058.106

SAVED: 3/20/2024 1:01 PM JMAULTY, PLOTTED: 3/26/2024 8:33 AM JUSTIS MAULTY
 P:\Willits\2021\421058-Noyo-CSP\106-Ice-Plant\Drawings\421058-106-PROJ-OVER.dwg



PLAN
 1" = 20'



PRELIMINARY

VERIFY SCALES
 BAR IS ONE INCH ON ORIGINAL DRAWING
 IF NOT ONE INCH ON THIS SHEET ADJUST SCALES ACCORDINGLY

535 S. MAIN ST
 WILLITS, CA 95490
 WWW.S&H-ELECTR.COM
 707-499-4518



NO.	DATE	REVISION	BY

DSSN	JGI
DR	CDN/JN
CHK	JGI
APVD	

NOYO HARBOR DISTRICT
 ICE HOUSE
 19101 S HARBOR DR., FORT BRAGG, CALIFORNIA
SITE PLAN

SHEET	C2.0
SEQ	
DATE	03/2024
PROJ. NO.	421058.106

SAVED: 3/20/2024 3:35 PM JMAULTY, PLOTTED: 3/26/2024 8:34 AM JUSTIS MAULTY
 P:\Willits\2021\421058-Noyo-CSP\106-lce-Plant\Drawings\421058-106-SITE.dwg

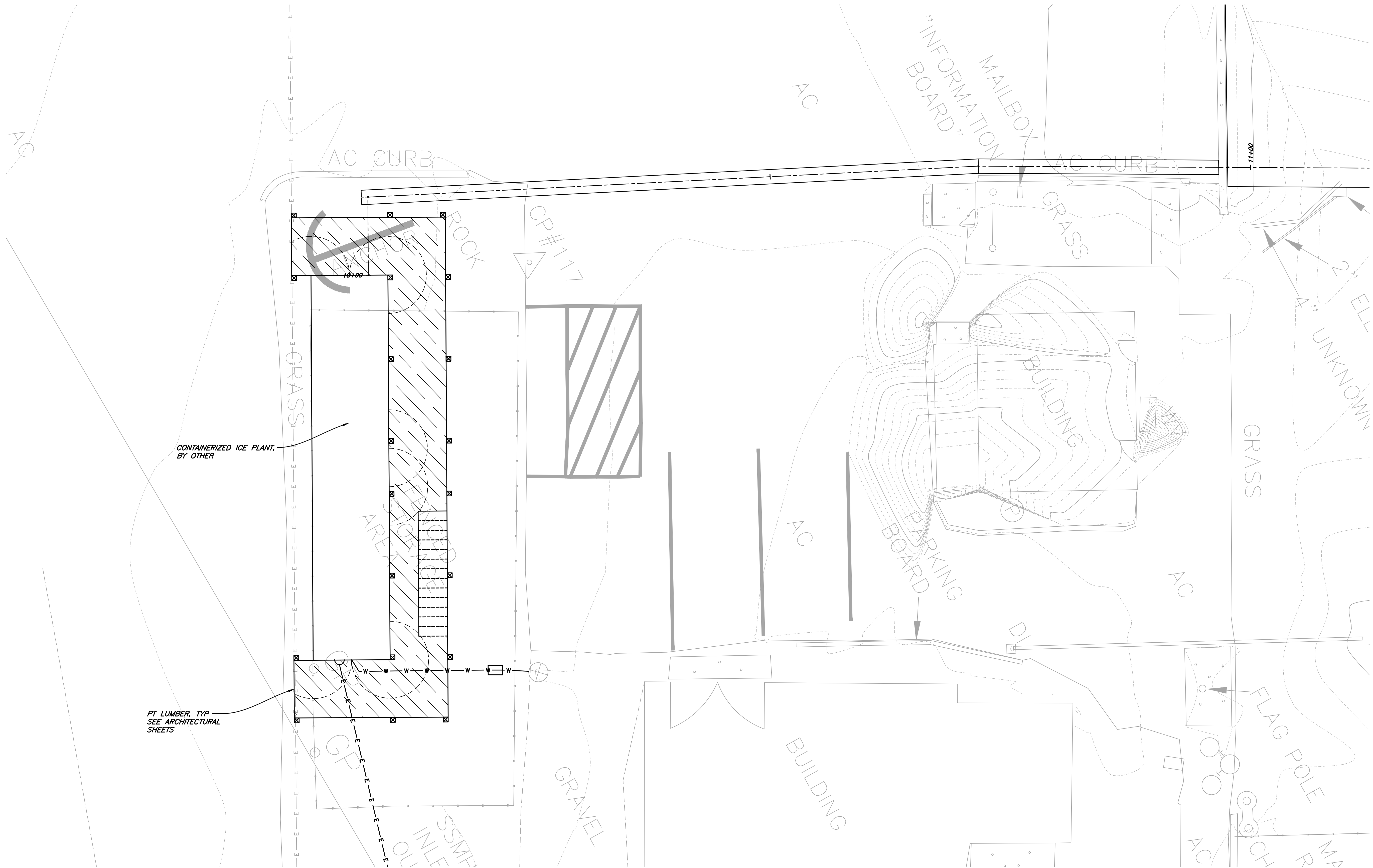

PT LUMBER, TYP
 SEE ARCHITECTURAL
 SHEETS

CONTAINERIZED ICE PLANT,
 BY OTHER

PLAN
 1"=10'



PRELIMINARY

VERIFY SCALES
 BAR IS ONE INCH ON
 ORIGINAL DRAWING
 O IF NOT ONE INCH ON
 THIS SHEET ADJUST
 SCALES ACCORDINGLY

535 S. MAIN ST
 WILLITS, CA 95490
 WWW.SHA-ENR.COM
 707-439-4518



NOYO HARBOR DISTRICT ICE HOUSE 19101 S HARBOR DR., FORT BRAGG, CALIFORNIA		DR	CDN/JN	NO.	DATE	REVISION	BY
ENLARGED SITE PLAN		CHK	JGI				
SHEET C2.1		APVD	JGI				
SEQ							
DATE 03/2024							
PROJ. NO. 421058.106							

SAVED: 3/20/2024 3:35 PM JMAULTY, PLOTTED: 3/26/2024 8:34 AM JUSTIS MAULTY
 P:\Willits\2021\421058-Noyo-CSP\106-Ice-Plant\Drawings\421058-106-SITE.dwg

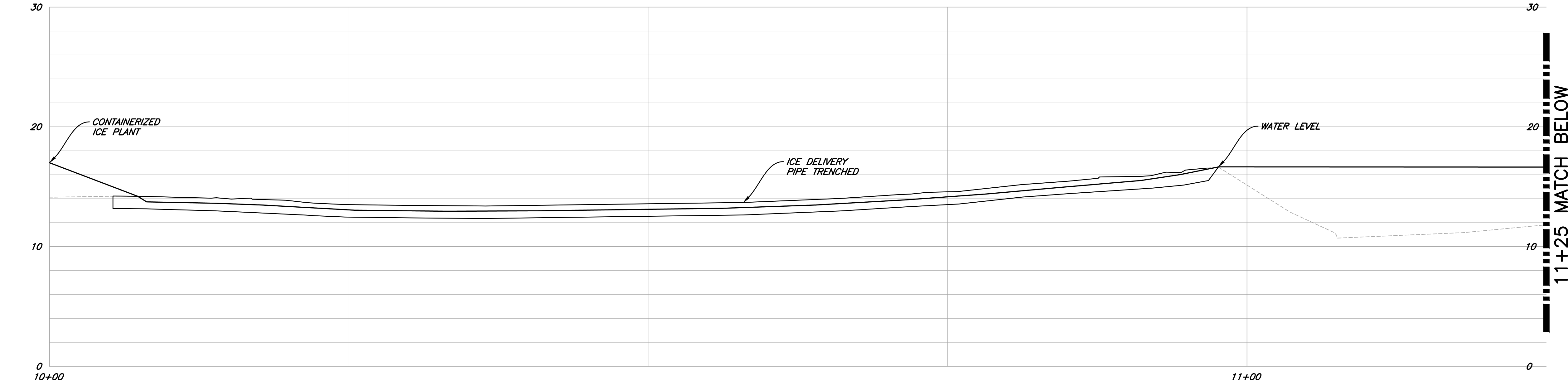

PROFILE
 1"=5' H&V



PROFILE
 1"=5' H&V

PRELIMINARY

VERIFY SCALES
 BAR IS ONE INCH ON ORIGINAL DRAWING
 IF NOT ONE INCH ON THIS SHEET ADJUST SCALES ACCORDINGLY

535 S. MAIN ST
 WILLITS, CA 95490
 WWW.S&W-ENR.COM
 707-439-4518



DESIGN	JGI	NO.	DATE	BY
DR	CDN/JN	REVISION		
CHK	JGI			
APVD				

NOYO HARBOR DISTRICT
 ICE HOUSE
 19101 S HARBOR DR., FORT BRAGG, CALIFORNIA
PROFILE

SHEET	C3.0
SEQ	
DATE	03/2024
PROJ. NO.	421058.106

SAVED: 3/20/2024 3:36 PM JMAULTY, PLOTTED: 3/26/2024 8:34 AM JUSTIS MAULTY
 P:\Willits\2021\421058-Noyo-CSP\106-Ice-Plant\Drawings\421058-106-DTL5.dwg

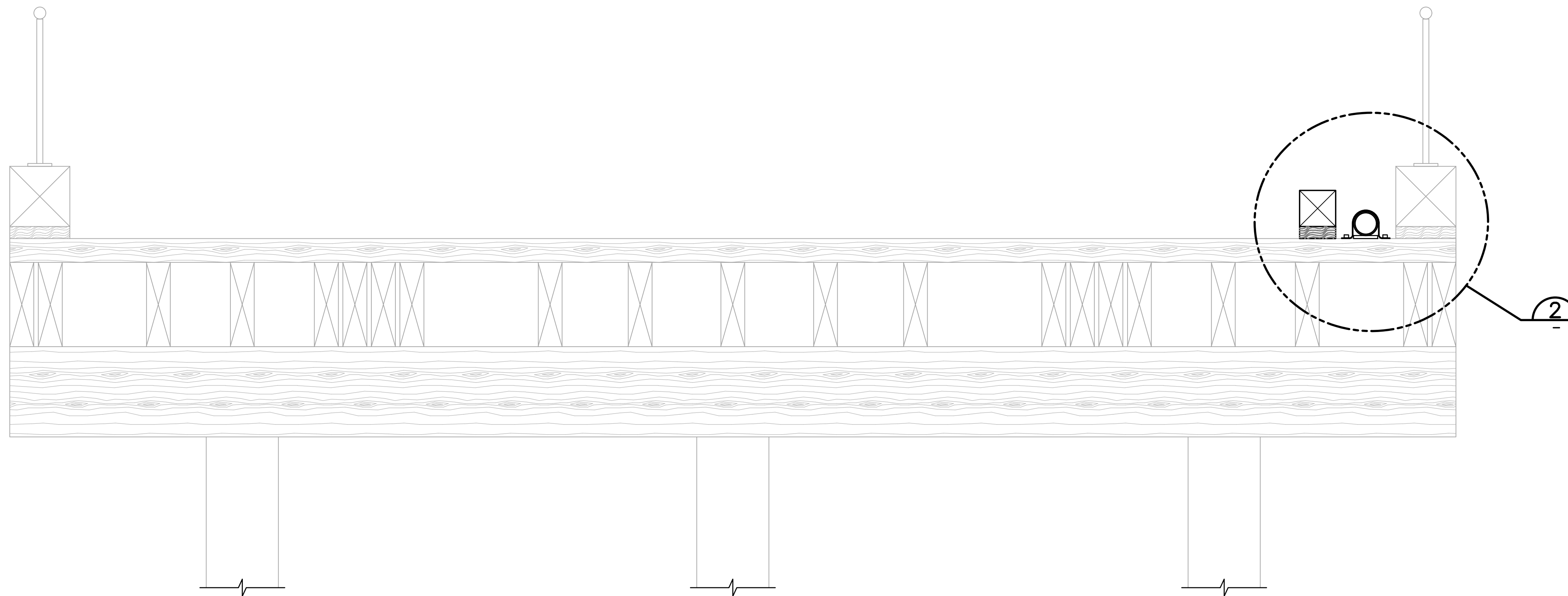

SECTION A
 NTS C1.0
 (HIGH DOCK)

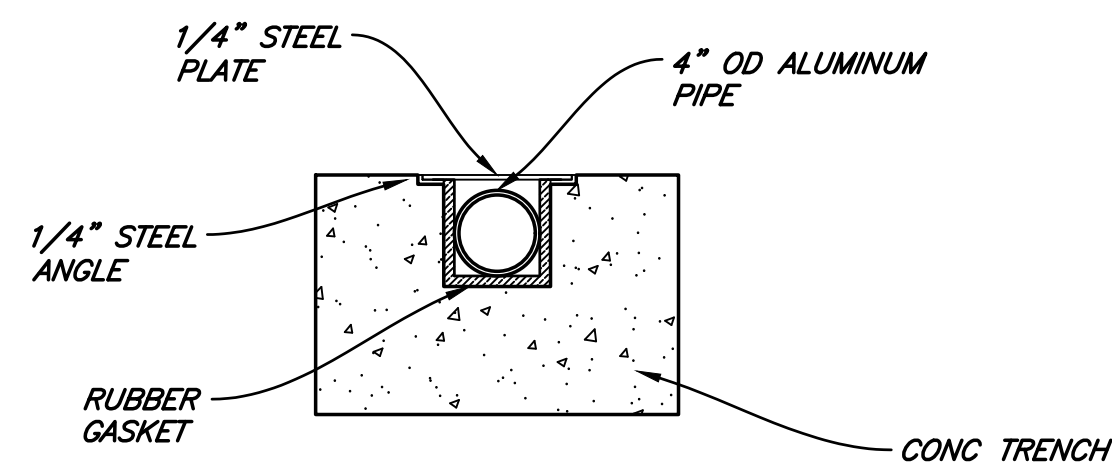

DETAIL 1
 NTS C1.0
 (ICE DELIVERY PIPE TRENCHED)

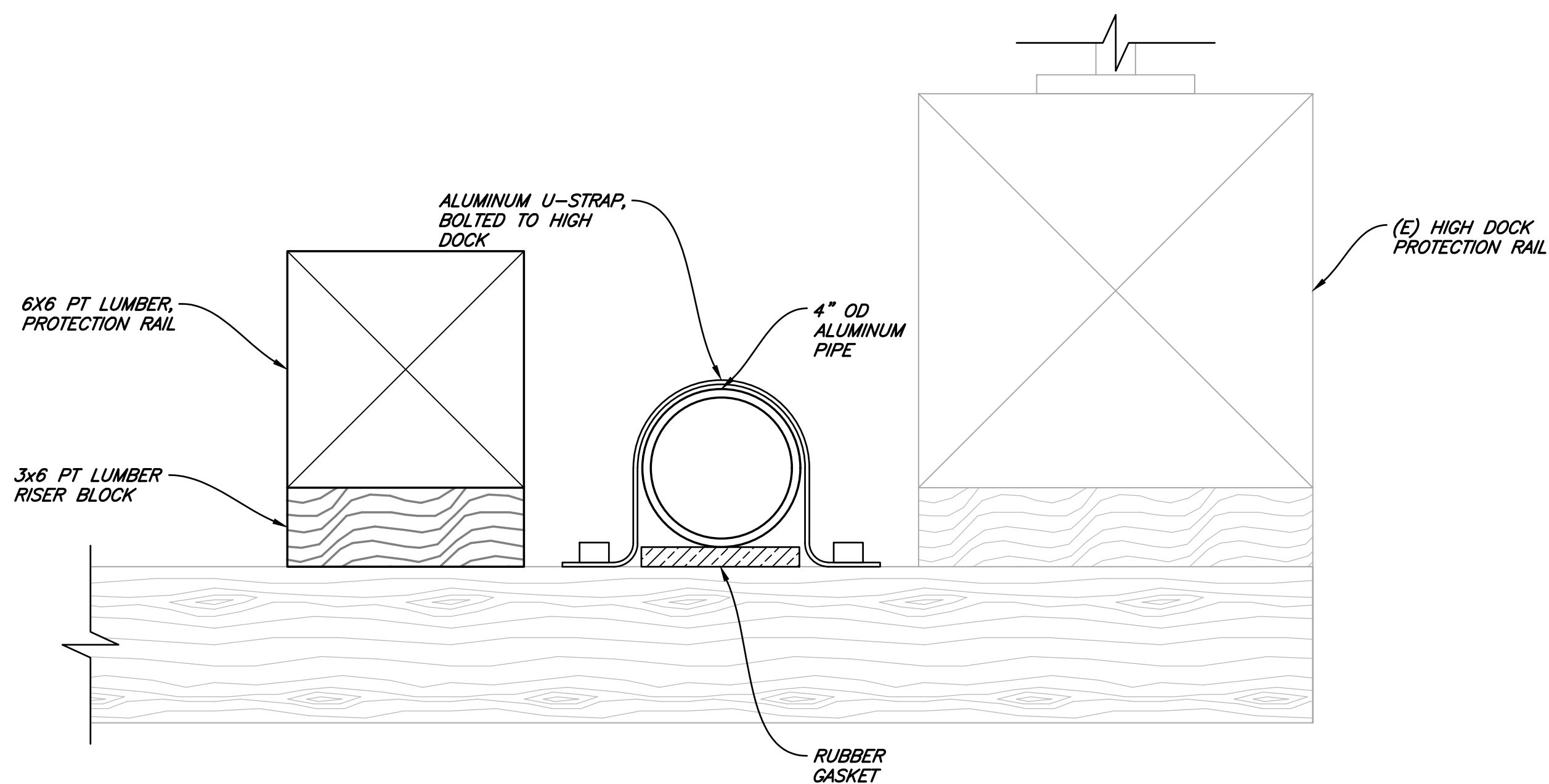

DETAIL 2
 NTS C1.0
 (ICE DELIVERY PIPE ON HIGH DOCK)

PRELIMINARY

VERIFY SCALES BAR IS ONE INCH ON ORIGINAL DRAWING IF NOT ONE INCH ON THIS SHEET ADJUST SCALES ACCORDINGLY	
535 S. MAIN ST. WILLITS, CA. 95490 WWW.S&H-ENR.COM 707-439-4518	
NO.	DATE
REVISION	BY
DSSN JGI DR CDN/JN CHK JGI APVD	NOYO HARBOR DISTRICT ICE HOUSE 19101 S HARBOR DR., FORT BRAGG, CALIFORNIA DETAILS
SHEET	C4.0
SEQ	
DATE	03/2024
PROJ. NO.	421058.106

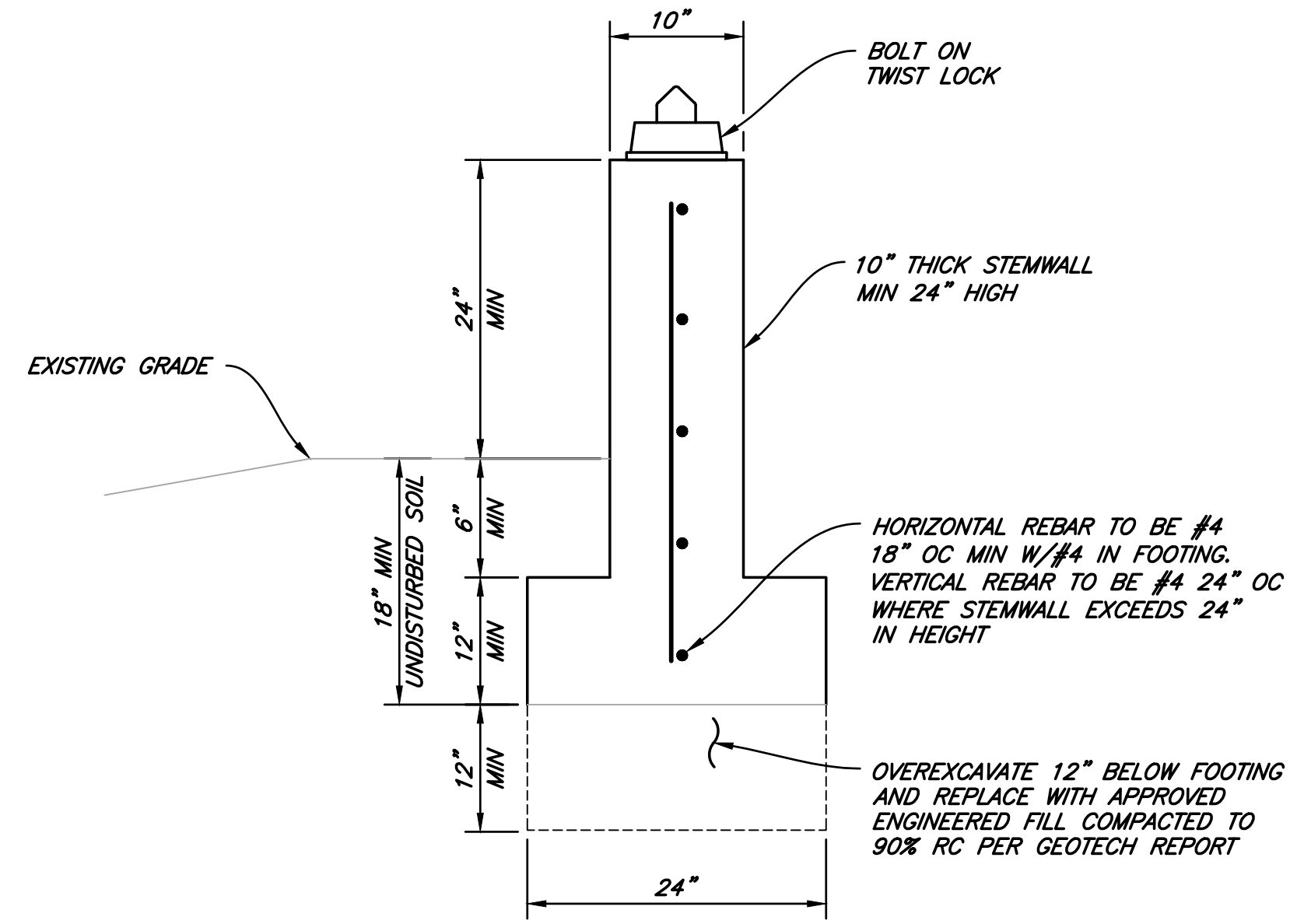

DETAIL 1
NTS
(PERIMETER FOOTING)

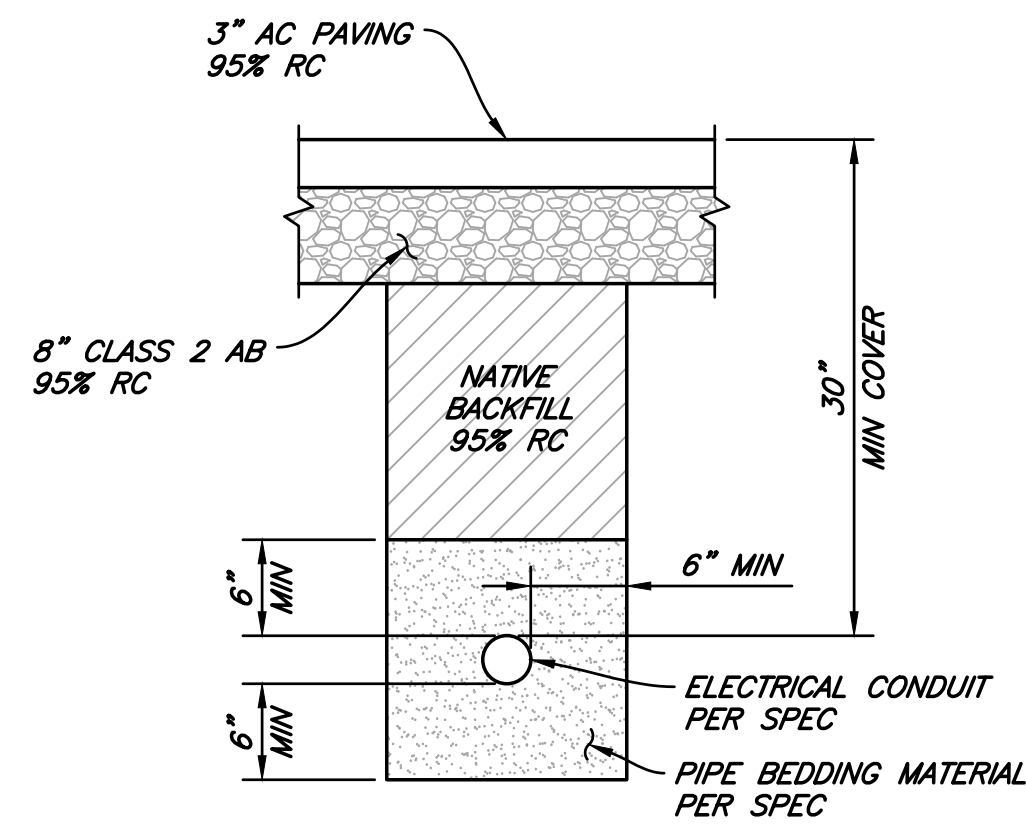

DETAIL 3
NTS
(ELECTRICAL LINE TRENCH)

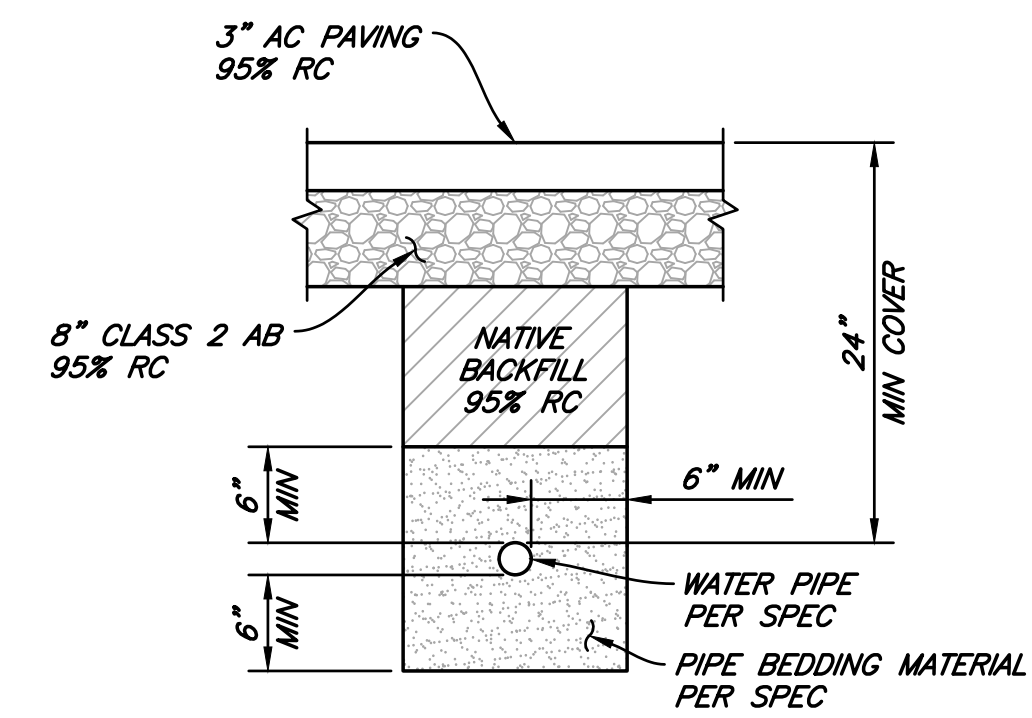

DETAIL 2
NTS
(WATER LINE TRENCH)



DETAIL 4
NTS
(BACKFLOW PREVENTER)

SAVED: 3/20/2024 3:36 PM JNAULTY, PLOTTED: 3/26/2024 8:34 AM JUSTIS NAULTY
P:\Willits\2021\421058-NOYO-CSP\106-ice-Plant\Drawgs\421058-106-DTL5.dwg

PRELIMINARY

VERIFY SCALES
BAR IS ONE INCH ON ORIGINAL DRAWING
IF NOT ONE INCH ON THIS SHEET ADJUST SCALES ACCORDINGLY

535 S. MAIN ST.
WILLITS, CA 95490
WWW.SHA-ENG.COM
707-439-4518

SHA

NO.	DATE	REVISION	BY

NOYO HARBOR DISTRICT
ICE HOUSE
DR., FORT BRAGG, CALIFORNIA

DETAILS

DR	CDN/JN	JGI	APVD

SHEET
C4.1

SEQ

DATE 03/2024

PROJ. NO.
421058.106

SAVED: 3/20/2024 2:59 PM JMAULTY, PLOTTED: 3/26/2024 8:34 AM JUSTIS NAULTY
 P:\Willits\2021\421058-Noyo-CSP\106-Ice-Plant\Drawings\421058-106-ARCH.dwg

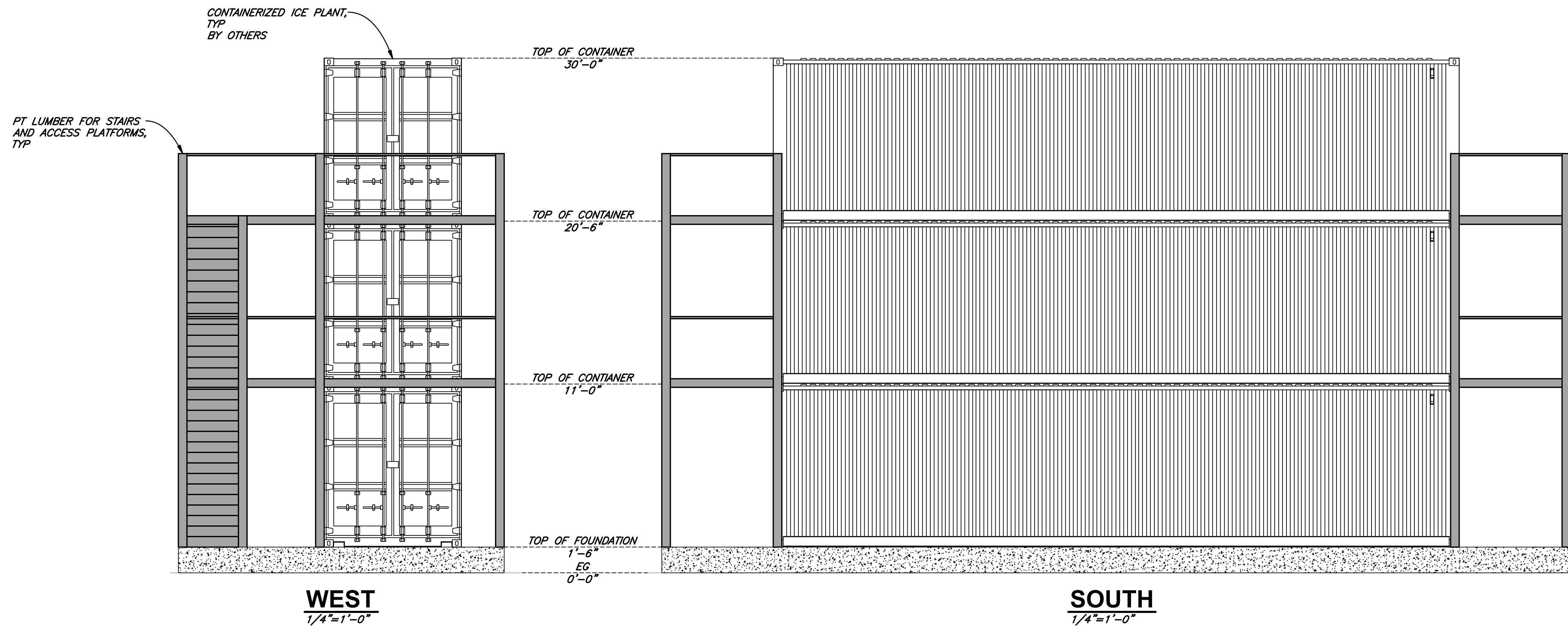
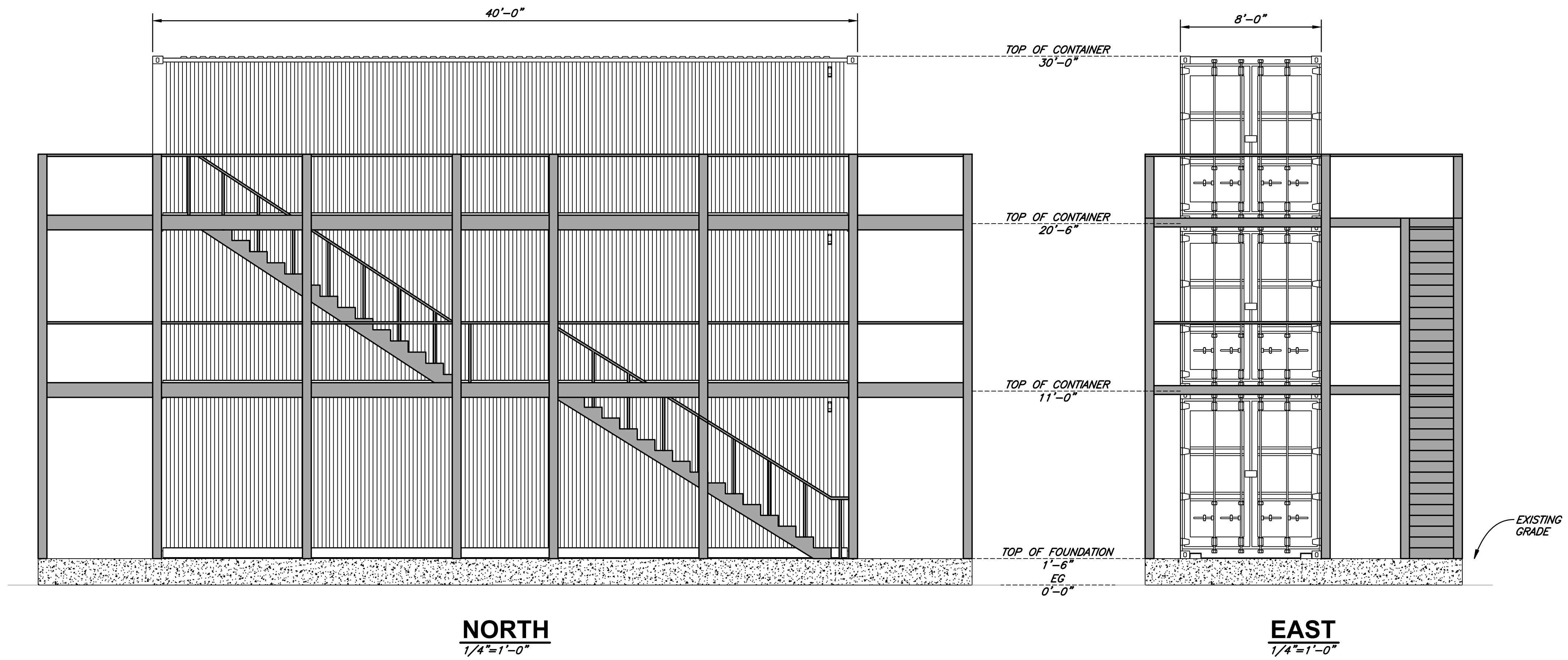

PRELIMINARY

VERIFY SCALES
 BAR IS ONE INCH ON ORIGINAL DRAWING
 IF NOT ONE INCH ON THIS SHEET ADJUST SCALES ACCORDINGLY

335 S. MAIN ST
 WILLITS, CA 95490
 WWW.SHA-ENG.COM
 707-499-4518

NO.	DATE	REVISION	BY

DR	CHK	APVD
JGI	JGI	JGI

NOYO HARBOR DISTRICT
 ICE HOUSE
 19101 S HARBOR DR., FORT BRAGG, CALIFORNIA
ELEVATIONS

SHEET
A1.0
 SEQ
 DATE **03/2024**
 PROJ. NO.
421058.106

Created Date	2/15/2024	QuoteNumber	A-5919
Account Name	Noyo Harbor District	Expiration Date	3/15/2024
Bill To	19101 S Harbor Dr Fort Bragg, CA 95437	Project Name	Container Ice Plant
		Project Location	CA

North Star Ice Equipment appreciates the opportunity to offer the following equipment for your requirement.

Quantity	Product	Line Item Description	Sales Price	Total Price
1.00	Dry Box Container	Ice Maker Module w/ One M60SS Flake Ice Maker, Control Panel and Refrigeration system per specifications	\$798,738.00	\$798,738.00
1.00	Container Rake	22 US Ton Flake Ice Container Rake System per specifications	\$272,695.00	\$272,695.00
1.00	Pneumatic Conveying System	Containerized Pneumatic Delivery System per specifications	\$254,795.00	\$254,795.00
1.00	Other	Start-up of Refrigeration Equipment per specifications	\$39,270.00	\$39,270.00

Subtotal	\$1,365,498.00
Total Price	\$1,365,498.00
Grand Total	\$1,365,498.00

Terms	50% Deposit, Balance Due 2 Weeks Prior to Shipping	*Estimated Delivery	20-24 Weeks from signed approval drawings and receipt of deposit, EX WORKS, Seattle WA
-------	--	---------------------	--

Banking Information

Key Bank of Washington
600 University St., Suite 2323
Seattle, WA 98101 USA

ABA # 125000574
SWIFT CODE # KEYBUS33SEA
NSI ACCOUNT # 586-0293-0

Note: All ice makers are designed to operate as part of a complete refrigeration system that includes refrigerant, condenser, compressor, and piping to be supplied by others.

***Delivery times are estimated at the time of quotation and are subject to change without notice. Quoted delivery times begin after receipt of Deposit and any applicable Signed Approval Drawings and Specifications.**

All other current North Star Ice Equipment Corporation Conditions of Sale apply to this quotation and any resulting Purchase Order. Please reference the **Quotation Number** when placing your order. We look forward to fulfilling this requirement.

Best Regards,



Logan Shepardson
President
North Star Ice Equipment Corp.



Page Left Blank

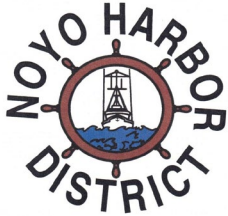

NOYO HARBOR DISTRICT AGENDA ITEM SUMMARY

AGENDA ITEM #: 4
MEETING DATE: 4/11/2024

TITLE

MCOG Noyo Harbor Multimodal Circulation Plan

RECOMMENDED ACTION

ANALYSIS

The Mendocino Council of Governments (*funded with federal FTA 5304 grant funding provided by Caltrans*) will study multimodal (pedestrian, bicycle, transit) access into and through the Noyo harbor where none currently exists, create a more efficient circulation pattern, look at improving safety by reducing conflicts between transportation modes, and create mode shift/reduce vehicle trips by providing non-vehicular and transit access to and through the harbor. It will study the feasibility of transitioning vehicular traffic through the harbor to one-way (to accommodate bike/ped in limited ROW) connecting N. Harbor Dr. to Noyo Point Rd on the west end of harbor (providing a secondary emergency evacuation route where none currently exists), and constructing a roundabout (or other intersection control) at the intersection on North Harbor Drive and State Route 1 (Main Street) to improve circulation and safety for all modes.

The final plan resulting from this study may be used by State, local, or tribal agencies (e.g., Caltrans, City of Fort Bragg, County of Mendocino, Noyo Harbor District, Mendocino Transit Authority, Sherwood Valley Band of Pomo Indians) to pursue next steps for planning, funding, and implementation of recommended multi-modal improvements.

Looking at the circulation of N. Harbor was listed as a priority project in the Community Sustainability Plan and the Harbor District has been requested to work with MCOG on their Technical Advisory Group.

FISCAL IMPACT

MCOG has not offered to reimburse for the Harbormaster time to attend TAG meetings, however meetings are one hour, once a month.

ATTACHMENTS

None



NOYO HARBOR DISTRICT AGENDA ITEM SUMMARY

AGENDA ITEM #: 5
MEETING DATE: 4/11/2024

TITLE

Marina Manager to full time position

RECOMMENDED ACTION

ANALYSIS

Through the recruitment process for the marina manager position it became clear that quality candidates were individuals looking for full-time work rather than part time work. Transitioning this position from part time to full time would allow the District to fill the position with a staff member qualified for this type of work.

With an understanding of the work loads in the office, the upcoming grant programs and the Harbormasters maternity leave and through conversations with Lead Maintenance it became clear that the Harbor could benefit from another full-time staff member. Particularly a staff member that can transition from office work to outside work as was described in the Marina Manager position.

FISCAL IMPACT

Offering a full time position comes with additional expense like benefits for the employee. Currently the Harbor District policy is to provide health, vision and dental insurance to all full-time employees. After 3 years, the employee is eligible for retirement.

In addition to cost to full time employees verse part time when considering employer taxes and contributions. For a full time employee employer taxes and contributions around roughly \$4,500 annually verse part time which is around \$2,000 annually

ATTACHMENTS

None



Page Left Blank



NOYO HARBOR DISTRICT AGENDA ITEM SUMMARY

AGENDA ITEM #: 6
MEETING DATE: 4/11/2024

TITLE

Financial Services RFQ

RECOMMENDED ACTION

ANALYSIS

The Harbor District released the RFQ for financial services and only received one response. The RFQ was emailed to individual firms that would be interested in responding and posted on the Harbor District website.

On re-contacting the one respondent, they were unable to commit to being with the Harbor District long term but could potentially help in the short term.

The Harbor may have better luck after tax season to re-release the RFQ or recruit a book keeper/financial services firm.

FISCAL IMPACT

ATTACHMENTS

None



Page Left Blank

Staff Report

Special meeting Noyo Center for Marine Science

A reminder to commissioners that the Noyo Center for Marine Science has requested a special meeting with the Commissioners to speak with their consultants for their Blue Economy Feasibility Study. The meeting will be April 23rd from 3-5pm at the Noyo Center Field Station previously known as the Slack Tide Café.

Application for Marina Redevelopment for State Coastal Conservancy

The Harbor Office is putting together a pre- application for the State Coastal Conservancy to fund the planning phase of Marina Redevelopment. Since the Harbor District was not successful in receiving a purchase agreement with the Mr. Daniel for the property acquisition project we have been invited to re-apply for a different project. A pre-application would be followed by a full application if the Conservancy finds the project to be within their scope of funding.